

Shark

Electromechanical underground operator
for swing gate leaves up to 3 m.



230V - 24V

The invisible solution for swing-gate operators.

High degree of protection against weathering, watertight motor completely in aluminum.

Built-in opening and closing leaf stops for quick-and-easy adjusting of the leaf-stopping point.

A smooth, safe movement guaranteed in all working conditions. Gate leaf standard opening angle up to 100 degrees and up to 180° with adaptor (optional accessory).

Foundation box cathaphoresis treated or inox.

Ideal solution for residential, industrial and apartment block settings.

Key-lock release system, protected by key.

The 24V range can operate in emergency mode during power outages by back-up batteries.



Swing gate automation



PROTECO S.r.l.
Via Neive, 77 - 12050 CASTAGNITO (CN) ITALY
Tel. +39 0173 210111 - info@proteco.net

Made in Italy



THE RANGE

	Power supply		Max leaf weight	Max leaf length
SHARK	230V	locked	3,0 m	350 Kg
SHARK 24	24V	locked	2,5 m	200 Kg

MOTOR POSITION

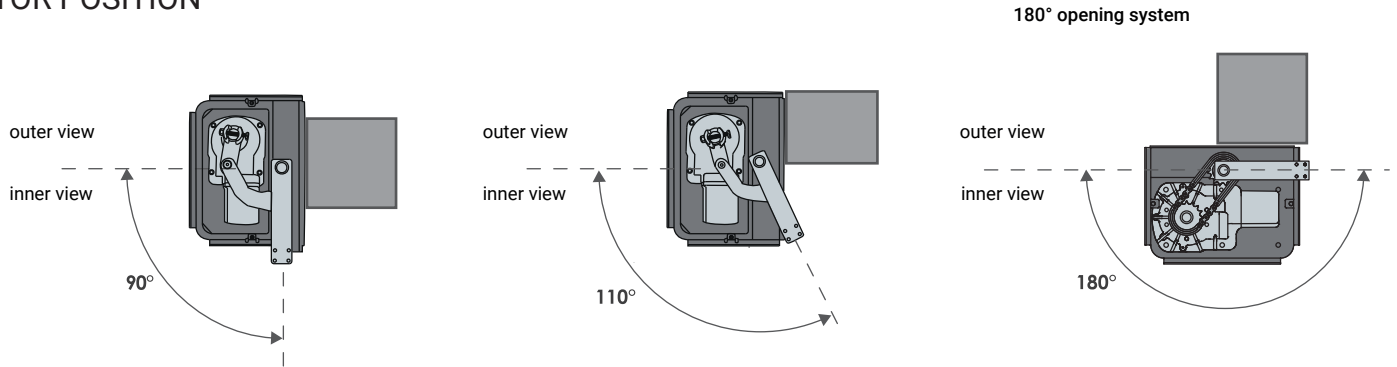

KIT CONTENT



SHARK
Underground motors complete with foundation box A001 (cataphoresis treatment)



LUCE
LED 24V flashing light



ANT02
Stand-alone antenna



IKON
Pair of 4-ch remote controls



RF40
Photocell



Q80A/Q20A
Control board integrated with plug-in radio receiver 433.92 MHz

DIMENSIONS

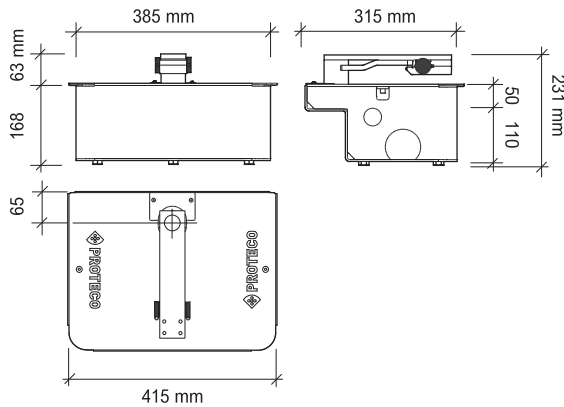

TECHNICAL FEATURES

	SHARK	SHARK 24
Power supply	230V ~ 50Hz	24V dc
Current	1.2 - 2A	0.5 - 0.75A
Motor power	300 W	50 W
Capacitor	10 µF	--
Thermic protection	150°C	--
Max thrust	350 Nm	230 Nm
IP protection class	66	66
Revolution speed	1400 rpm	1600 rpm
Max opening angle	110°	110°
90° angle opening time	17"	16"
Max leaf weight	350Kg	200 Kg
Max leaf length	3 m	2,5 m
Duty cycle	50%	90%

INSTALLATION MAP

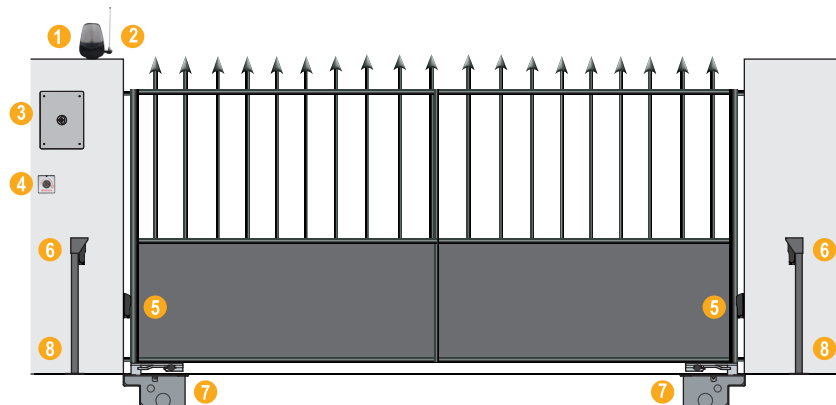

- 1_Flashing light
- 2_Outstanding antenna
- 3_Control board
- 4_Key switch
- 5_Outer photocell
- 6_Inner photocell
- 7_Gear motors complete with foundation box
- 8_Phocell posts