

LEADER TA



Attuatore elettromeccanico a TUBO ASOLATO per cancelli battenti con anta fino a 2,8 m.

230V - 115V - 24V

Compatto, potente e silenzioso.
Sistema di trasmissione a vite senza fine con ingranaggio in bronzo.
Montaggio facile e veloce, adatto a qualsiasi contesto di installazione.
Versione FM con fermo meccanico regolabile in chiusura.
Per uso residenziale, condominiale e commerciale.
Sblocco manuale di emergenza a leva, protetto da serratura a chiave.
Possibilità di alimentazione di soccorso a batteria nelle versioni 24V.

Electromechanical operator for swing gate leaves up to 2,8 m.

230V - 115V - 24V

Slick design, silent and powerful performance.
Fully covered and protected endless screw, bronze transmission shaft.
Suitable to any context, easier installation and start-up.
FM version, integrated with on-board mechanical stops, for controlling gate travel.
Ideal solution for residential, industrial and apartment block settings.
Key-lock release system, protected by encrypted key.
The 24V range can operate in emergency mode during power outages by back-up batteries.



Automazioni per cancelli a battente
Swing gate automation

 **PROTECO**
GATE AUTOMATIONS

LA GAMMA

	Power supply Alimentazione			Max leaf weight Anta max.	Max leaf length Peso max.
LEADER 4 TA	230V/115V	irreversibile	locked	2,75 m	350 Kg
LEADER 4 TA FM	230V/115V	irreversibile	locked	2,75 m	350 Kg
LEADER 4 TA 24	24V	irreversibile	locked	2,5 m	200 Kg
LEADER 4 TA FM	24V	irreversibile	locked	2,5 m	200 Kg

THE RANGE

DIMENSIONI

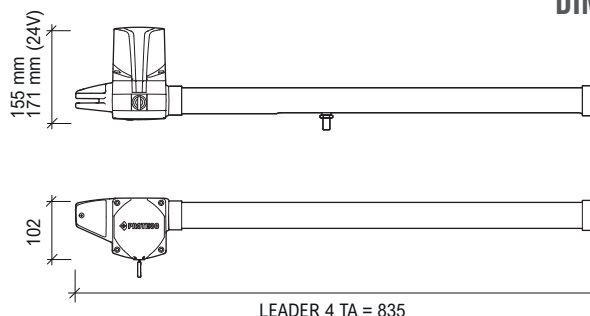

DIMENSIONS

COMPOSIZIONE KIT



LEADER TA
Coppia attuatori a tubo protetto con staffe di fissaggio

Pair of swing motors and fittings



LUCE
Lampeggiatore LED 24V

LED 24V flashing light



ANT02
Antenna da esterno

Aerial 433,92 Mhz



ANGIE
2 Trasmittitori 4 canali

Pair of 4-ch remote controls



RF40
Coppia fotocellule

Photocell set



Q80A/Q20A
Centrale di gestione con ricevitore 433,92 MHz

Control board integrated with plug-in radio receiver 433.92 MHz

KIT CONTENT

CARATTERISTICHE TECNICHE

	LEADER 4 TA	LEADER 4 TA 115V	LEADER 4 TA 24V	
Alimentazione	230V ~ 50Hz	115V ~ 60Hz	24V dc	Power supply
Assorbimento	1.7A	2.3A	0.75A	Current
Potenza	280 W	300 W	50 W	Motor power
Condensatore	8 µF	30 µF	--	Capacitor
Protezione termica	150°C	150°C	--	Thermic protection
Spinta massima	2800 N	3000 N	2500 N	Max thrust
Protezione IP	44	44	44	IP class protection
Giri motore	1400 rpm	1700 rpm	1700 rpm	Revolution speed
Angolo max di apertura	100°	110°	110°	Max opening angle
Tempo apertura 90°	22"	18"	18"	90° opening time
Peso anta massima	350 Kg	200 Kg	200 Kg	Max leaf weight
Lunghezza anta massima	2.75 m	2.75 m	2.50 m	Max leaf length
Ciclo di lavoro	40%	40%	80%	Duty cycle

TECHNICAL FEATURES

SCHEMA D'INSTALLAZIONE

- 1_Lampeggiatore
- 2_Antenna da esterno
- 3_Centrale di comando
- 4_Selettore a chiave
- 5_Fotocellule CHIUSURA
- 6_Fotocellule APERTURA
- 7_Attuatori
- 8_Colonnina fotocellule

INSTALLATION MAP

- 1_Flashing light
- 2_Outstanding antenna
- 3_Control board
- 4_Key switch
- 5_Outer photocell
- 6_Inner photocell
- 7_Swing operators
- 8_Photocell posts

